

# MMG45IF4 | 2.2 L | 45 kVA

## MOBILE DIESEL GENERATOR SET

EPA Emissions Certification: Tier 4 Final

### Standby Power Rating

44 kW, 55 kVA, 60 Hz

### Prime Power Rating

38 kW, 47 kVA, 60 Hz



\*Assembled in the USA using domestic and foreign parts



Picture shown may not reflect actual configuration.

## Codes and Standards

Generac Mobile products are designed to the following standards:



CSA



NATM



TIER 4 FINAL EMISSIONS

## Power When You and Where You Need It

Generac Mobile generators are designed and engineered to power a variety of projects, in the most extreme environments. Gensets are configured to meet customer needs, including choice of containment, cold weather packages, trailer options, and more.

Generac Mobile generators are manufactured to deliver reliable power, when and where you need it.

**STANDARD FEATURES**

**ENGINE SYSTEM**

- Isuzu® 4LE2XAGV01
- 4 cylinder
- Turbocharged & Aftercooled
- 134 in<sup>3</sup> (2.2 L) Displacement
- EPA Tier 4 Final
- Power @ 1,800 RPM -hp (kW):
  - Prime: 57 (42.8)
  - Standby: 63.7 (47.5)
- Paper Element Air Filter
- Electronic Isochronous Governing
- Fixed Speed Fan
- Spin On Cartridge Oil Filter
- Oil Drain Extension
- Two Fuel Filters
- One 12 V, 720 CCA, Wet Cell Battery

**COOLING SYSTEM**

- Capable of Operating at 120 °F (49 °C) Ambient
- 50/50 Coolant (50% Ethylene Glycol)
- Coolant Drain Extension

**WARRANTY**

- 2 year limited or 2,000 hours
  - Unlimited hours covered in first year

**FUEL SYSTEM**

- Polyethylene Fuel Tank
- Fuel Tank Capacity — US gal (L):
  - Total: 100 (379)
  - Usable: 90 (341)

**FUEL SYSTEM (CONTINUED)**

- Maximum Runtime @ 75% load: 36 hr
- 110% Containment - engine fluid (oil & coolant) and fuel
- Padlockable Fuel Cap

**CONTROL SYSTEM**

- Deep Sea Electronics® 7310 MKII Controller
- 3-Position Voltage Selection Switch
- 225 A Main Circuit Breaker (MCB), Manual, with Shunt Trip
- Individual Convenience Receptacle Circuit Breakers
- Emergency Stop Switch
- Battery Disconnect Switch, Padlockable
- Remote 2-wire Start/Stop Contacts

**ALTERNATOR SYSTEM**

- 60 Hz Engine-Driven Alternator
- SUPERSTART Alternator
  - Brushless
  - 4 Pole
  - 2/3 pitch
  - Class H insulation
  - Corrosion Protection
- Marathon Electric® PM500 AVR
- Shunt Excitation System

**POWER DISTRIBUTION**

- Connection Lugs

**POWER DISTRIBUTION (CONTINUED)**

- Convenience Receptacles
  - Two 120 V, 20 A, GFCI Duplex (NEMA 5-20R)
  - Three 120/240 V, 50 A, 3 Pole, 4 Wire Twist-lock (CS6369)

**ENCLOSURE**

- Aluminum, Sound Attenuated Enclosure, Insulated and Baffled
- UV and Fade Resistant, High Temperature Cured, White Polyester Powder Paint
- Central Lifting Point
- Fully Lockable Enclosure
- Multi Lingual Operating and Safety Decals
- Document Holder with Owner's Manual - includes AC and DC wiring diagrams
- Control Panel Lights
- Interior Lights

**TRAILER**

- Hydraulic Surge Brakes
- 2 in. (50.8 mm) Ball Hitch
- Single 6,000 lb (2,722 kg) Axle
- Tires: ST225/75, 15 in. Rim
- 2,000 lb. (907 kg) Tongue Jack with Footplate
- Safety Chains with Spring Loaded Safety Hooks
- Transportation Tie Downs
- Plug Adapter, Round 7 Spade (SAE J2863)
- DOT Approved Tail, Side, Brake, and Directional Lights

**CONTROL SYSTEM**

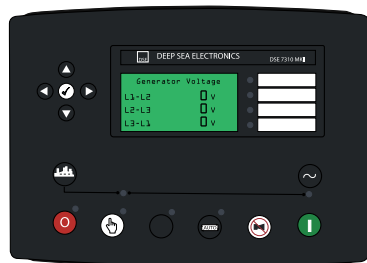

**Deep Sea Electronics CONTROLLER AND DISPLAY**

- Model DSE7310 MKII
- 4 Line Back Lit LCD Text Display
- -40 to 158 °F (-40 to 70 °C) Operating Temperature Range
- Multiple Language Options
- Configurable Timers and Alarms
- Configurable Start/Stop Timers
- Configurable Maintenance Alarms
- Heated Display

**PUSH BUTTONS FOR EASY OPERATION**

- Manual or Auto Start
- Engine Start
- Engine Stop/Reset
- User Friendly Setup and Button Layout
- Five Key Menu Navigation
- Multiple Parameters are Monitored and Displayed Simultaneously for Full Visibility
- View Controller Parameters (Configuration, Firmware Version, Connections)

**ELECTRICAL CONTROLS**

- Lockable Control Box Door with Diagnostics Window
- Lockable lug box with safety switch
  - Trips main breaker when door is opened
  - Disables voltage regulator
- Output ground connection lug inside lug box
- Voltage adjustment ±10%

**LCD ALARM INDICATION**

- Generator Diagnostic Display

- System kVA Output Display
- Line Output and Frequency Display
- Alarm Types: Warning, Shutdown, Electrical Trip, Engine
- Alarm List – Warnings/Shutdowns; 250 Event History Log – Date/Time Stamped
  - Fuel Level: Warning – 15%; Shutdown – 5%
  - Overspeed Protection: Shutdown – 110%
  - Engine Diagnostic Warnings Communicated Through J1939 CANbus
  - Battery Voltage: Over – 15 VDC; Under – 11 VDC
  - Generator Over Voltage: Warning – 110%; Electrical Trip – 115%
  - Generator Under Voltage: Warning – 90%; Shutdown – 85%
  - Generator Over Frequency: Warning – 105%; Electrical Trip – 110%
  - Generator Under Frequency: Warning – 95%; Electrical Trip – 90%
- Auto Schedule
- Status

# MMG45IF4 | 2.2 L | 45 kVA

## MOBILE DIESEL GENERATOR SET

EPA Emissions Certification: Tier 4 Final

**GENERAC** | MOBILE

### CONFIGURABLE OPTIONS\*

#### ENGINE SYSTEM

- Positive Air Shutdown (PAS), Electronic
- One 12 V, 720 CCA AGM Optima Battery
- Alternate Load Device (ALD)
- Oil Evacuation System - requires customer-sourced, specialized equipment to use for oil change

#### COLD WEATHER

- Engine Block Heater
- Two Heated Fuel Filters
- Crankcase Ventilation (CCV) System Heater
- 10 A Battery Charger
- 60/40 Coolant (60% Ethylene Glycol)

#### CONTROL SYSTEM

- 4-Position Voltage Selection Switch
- Telemetry

#### FUEL SYSTEM

- Steel Fuel Tank, Extended Runtime
- Fuel Tank Capacity—US gal (L)
  - Total: 160 (606)
  - Usable: 144 (545)
- Runtime @ 75% Load: 57.5 hr
- Auxiliary Fuel Tank Connection
  - 3-Way Fuel Valve

#### ALTERNATOR SYSTEM

- VFLEX (600 V) Alternator
- Marathon Electric® DVR2400 DVR
- Permanent Magnet Generator (PMG) Excitation System

#### POWER DISTRIBUTION

- Camlocks—one set, female (US or Canada color code)
- Buck Transformer

#### ENCLOSURE

- Fire Extinguisher

#### TRAILER

- Skid Mount (Non-trailer)
- Electric Brakes
- Tandem Axle
- 2 in (50.8 mm) BULLDOG® Hitch
- 2-5/16 in (58.7 mm) BULLDOG Hitch
- 3 in (76.2 mm) Pintle Ring Hitch
- Rear Stabilizer Jacks
- Toolbox Aluminum, 49 x 15 x 18.5 in. (125 x 38 x 47 cm)
- Spare Tire

### RATING DEFINITIONS

*Standby: Applicable to varying emergency load for the duration of a utility power outage.*

*Prime: Applicable to supplying power to a varying load in lieu of utility for an unlimited amount of running time.*

\*Consult factory for availability



**APPLICATION AND ENGINEERING DATA**
**ENGINE SPECIFICATIONS**
**General**

Make (Model)	Isuzu (4LE2XAGV01)
EPA Emissions Compliance	Tier 4 Final
After Treatment System	DOC
Cylinder #	4
Type	In-line
Displacement: in <sup>3</sup> (L)	134 (2.2)
Bore: in (mm)	3.35 (85)
Stroke: in (mm)	3.78 (96)
Compression Ratio	17.6:1
Intake Air Method	Turbocharged & Aftercooled

**Engine Governing**

Governor	Electronic
Frequency Regulation (Steady State)	2%

**Lubrication System**

Oil Pump	Gear Driven
Oil Filter Type	Spin-On Cartridge, Full Flow
Engine Oil Capacity: qt (L)	12 (11.4)

**Cooling System**

Cooling System Type	Radiator and CAC
Water Pump Type	Engine Belt Driven
Fan Type	Pusher
Fan Speed: RPM	2,016
Fan Diameter: in (mm)	19.0 (48.3)
Cooling System Capacity – qt (L)	18 (17)

**Fuel System**

Fuel Type	Ultra Low Sulfur Diesel
Fuel Specifications	EN 590 / ASTM D975
Fuel Filtering	5
Fuel Injection Pump – Make (Model)	Denso (HP3)
Fuel Pump Type	Engine Gear Driven
Injector Type	Electronic
Engine Type	Direct Injection High Pressure Common Rail
Fuel Supply Line Diameter – in (mm)	0.375 (9.5)
Fuel Return Line Diameter – in (mm)	0.375 (9.5)

**Engine Electrical System**

System Voltage: VDC	12
Battery Charger Alternator – VDC (A)	12 (50)
Battery – CCA	720
Battery – V (Qty)	12 (1)
Ground Polarity	Negative (-)

**SUPERSTART ALTERNATOR SPECIFICATIONS**

Make (Model)	Marathon Electric (285PSL1700)
Poles	4
Field Type	Rotating
Insulation Class – Rotor	Class H
Insulation Class – Stator	Class H
Total Harmonic Distortion (THD)	<5%
Telephone Interference Factor (TIF)	<50

Standard Excitation	Shunt
Bearings	Single Bearing
Coupling	Direct Flexible Disc
Prototype Short Circuit Test	Yes
Voltage Regulator Type	AVR
Quantity of Sensed Phases	Single
Regulation Accuracy (Steady State)	±0.5%

**VFLEX ALTERNATOR SPECIFICATIONS**

Make (Model)	Marathon Electric (284PSL28109)
Poles	4
Field Type	Rotating
Insulation Class – Rotor	Class H
Insulation Class – Stator	Class H
Total Harmonic Distortion (THD)	<5%
Telephone Interference Factor (TIF)	<50

Standard Excitation	Shunt
Bearings	Single Bearing
Coupling	Direct Flexible Disc
Prototype Short Circuit Test	Yes
Voltage Regulator Type	AVR
Quantity of Sensed Phases	Single
Regulation Accuracy (Steady State)	±0.5%

**OPERATING DATA**

**POWER RATINGS**

	SUPERSTART Alternator		VFLEX Alternator	
	Standby:	Prime:	Standby:	Prime:
	kW/kVA (A)	kW/kVA (A)	kW/kVA (A)	kW/kVA (A)
1-Phase, 120/240 VAC @ 1.0pf-zig zag*	33/33 (138)	33/33 (138)	17/17 (71)	17/17 (71)
3-Phase, 208/120 VAC @ 0.8pf-low wye	44/55 (153)	38/47 (130)	38/48 (131)	32/40 (111)
3-Phase, 240/120 VAC @ 0.8pf-delta**	44/55 (132)	38/47 (114)	38/48 (114)	32/40 (96)
3-Phase, 480/277 VAC @ 0.8pf-high wye	44/55 (66)	38/47 (57)	48/59 (72)	37/46 (56)
3-Phase, 600/346 VAC @ 0.8pf-high wye	N/A	N/A	46/60 (52)	40/50 (48)

\*Alternator limited.

\*\*Power ratings achieved through use of optional 4-position voltage selection switch.

**FUEL CONSUMPTION RATES**

Prime Load	Fuel: gph (L/hr)
50%	1.7 (6.4)
75%	2.5 (9.4)
100%	3.3 (12.5)
110% (Standby)	3.8 (14.4)

Deration – Operational characteristics consider maximum ambient conditions. Derate factors may apply under atypical site conditions.

Please consult a Generac Mobile Authorized Service Dealer for additional details. All performance ratings in accordance with ISO3046, BS5514, ISO8528, ISO8665, ISO3046, SAE J1228, SAE J1995, and DIN6271 standards.

# MMG45IF4 | 2.2 L | 45 kVA

## MOBILE DIESEL GENERATOR SET

EPA Emissions Certification: Tier 4 Final



### DIMENSIONS AND WEIGHTS\*

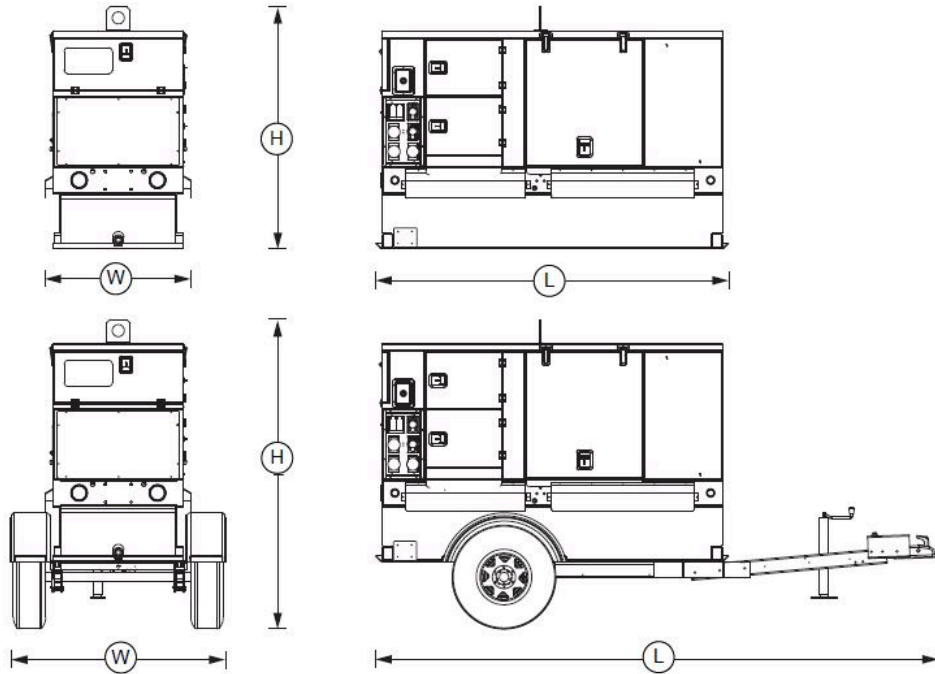

	Runtime: hr*	Usable Fuel Capacity: gal (L)	Dimensions – L×W×H: in (m)	Weight: lb (kg)
Skid	36	90 (341)	95 (2.41)×39 (0.99)×65 (1.65)	Dry: 2,843 (1,290) Operating: 3,580 (1,624)
Trailer	36	90 (341)	152 (3.81)×58 (1.45)×83 (2.11)	Dry: 3,363 (1,525) Operating: 4,100 (1,860)

\*Runtime based on 75% of prime rated power

### SOUND RATING

- 66 dB(A) @ 23 ft (7 m) @ Prime Power

\* All measurements are approximate and for estimation purposes only.

YOUR FACTORY RECOGNIZED GENERAC MOBILE DEALER

Specification characteristics may change without notice. Dimensions and weights are for preliminary purposes only. Please consult a Generac Mobile Authorized Service Dealer for detailed installation drawings.