

MLT4060MK/MLT4080K

MOBILE LIGHT TOWER

GENERAC | MOBILE

ENGINE SYSTEM

- MLT4060M - Mitsubishi LE3 with
 - Prime hp/kW: 10.5 / (7.8)
 - 0.95L displacement
- MLT4060K - Kubota D1005
 - Prime hp/kW: 11.7 (8.7)
 - 1.00L displacement
- MLT4080K - Kubota D1105
 - Prime hp/kW: 13.5 (10.1)
 - 1.12L displacement
- Air filter: Dry type cartridge

Fuel System

- Polyethylene tank
- Tank volume: 56 US gal (212 L)
- Run time (hrs) with lights-only and at 100% load:*
- MLT4060M: 186/95
- MLT4060K: 183/86
- MLT4080K: 165/66

Cooling System

- Liquid cooled
- 50/50 glycol/water mixture (standard)
- 60/40 glycol/water mixture (optional)

Lubrication System

- Oil filter: Full flow, spin-on type
- 1,000-hr service interval*

GENERATOR

- 120/240 VAC 60 Hz generator
- Marathon[®] brushless 201CSA5411 (6kW), 201CSA5420 (8kW)
- Output
 - MLT4060 - 6kW, $\pm 6\%$ voltage regulation - capacitor
 - MLT4080 - 8kW, $\pm 1\%$ voltage regulation - AVR

CONTROLS

- Analog key-activated ignition with optional digital control with automatic scheduling
- Engraved, aluminum punched and anodized control panel
- Toggle switch for raising and lowering mast
- ON-OFF switch for each light fixture
- Digital hour meter
- Automatic shutdown for low oil pressure and high coolant temperature

*Data based on engine manufacturer and field test data after 50-hr engine break-in period. Actual results may vary, according to factors such as age and maintenance of equipment, environmental conditions, and fuel density

For fuel and maintenance recommendations, see owner's manual.



Picture shown may not reflect actual configuration.

MLT4060MK/MLT4080K

MOBILE LIGHT TOWER

SPECIFICATIONS

FLOODLIGHTS

- Four 320W LED (G5) luminaires
 - Lm/fixture: 49,600
 - Total lm: 198,400
- Efficiency: 155 LPW
- Coverage at 0.5 ft-c: 30,020 ft² / 2,789 m²
- Aluminum and polymer housing
- IP68 LED modules; IP65 rated drivers
- Fixture-mounted drivers
- Friction disc mounting for tool-free positioning

ELECTRICAL SYSTEM

- Shunt trip equipped main circuit breaker that ensures no-load start-up
- Individual floodlight circuits with 5A breakers
- **MLT4060** Convenience receptacles with individual breakers:
 - One 120 VAC, 20A, GFCI, duplex outlets (NEMA 5-20R)
 - One 240 VAC, 30A, twistlock outlets (NEMA L14-30R)
- **MLT4080** Convenience receptacles with individual breakers:
 - One 120 VAC, 20A, GFCI, duplex outlets (NEMA 5-20R)
 - Two 240 VAC, 30A, twistlock outlets (NEMA L14-30R)
- 440 CCA wet cell battery

MAST

- Vertical operation and storage
- Four tubular steel sections with polymer guides
- Winch: Electric, self-braking with guard
- Distinctive angled fixture mount for common light
- 359° rotation, lockable and adjustable from ground with mast fully extended
- Industrial-black powder-coat
- Self-retracting, coiled mast cord
- Winch cable guard

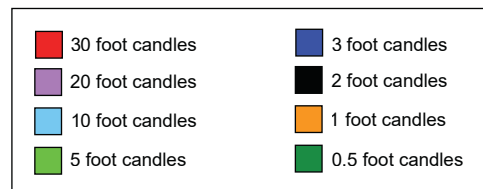
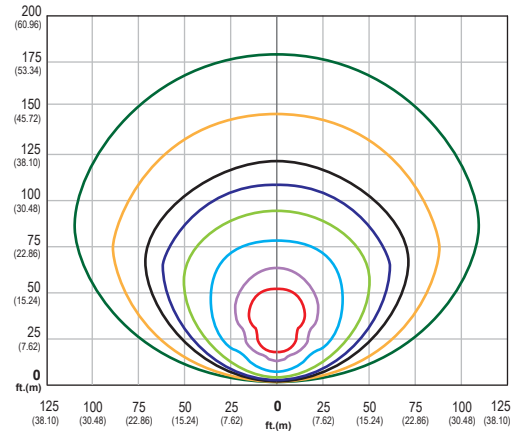

Area illuminated by 0.5 foot-candles or more:
30,020 ft² (2,789 m²)

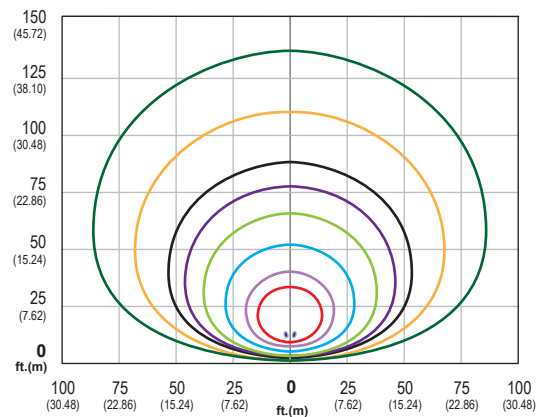

Area illuminated by 0.5 foot-candles or more:
18,170 ft² (1,688 m²)
(Coverage is with optional diffuse lens kit installed)

MLT4060MK/MLT4080K

MOBILE LIGHT TOWER

GENERAC | **MOBILE**

ENCLOSURE

- Heavy-duty, 14-gauge steel
- Stainless steel hinges on doors
- UV & fade resistant, high temperature cured, white polyester powder paint
- Sound rating: 68 dB(A) at 23 ft (7 m) @ prime power
- Lifting point and fork pockets
- Multi-lingual operating and safety decals
- Illuminated license plate holder
- Document holder with owner's manual – includes AC and DC wiring diagrams

TRAILER

- Tubular steel frame
- Removable tongue - 48 in (1.2 m) length
- 2 in (50 mm) ball hitch
- Four 2,000 lb (907 kg) leveling jacks - lockable into stowed positions
- Side outriggers
- 7,800 lb (3,538 kg) safety chains with spring loaded safety hooks
- DOT approved LED lights: Tail, side, brake, and directionals
- 3,000 lb (1,361 kg) leaf spring axle
- Single wall polyethylene fenders
- Tires: P205/75R15
- Front step platform for easy adjustment of light fixtures

COLD-WEATHER OPTIONS

- 60/40 coolant
- Coolant heater
- Heated fuel filter
- 720CCA AGM sealed battery
- Liquid containment
- Battery charger - 10 A, 3-Stage

OTHER OPTIONS*

- Various trailer hitch types
- Flat 4 to round 7 spade
- Positive air shutoff (PAS)
- Ground rod
- 5 lb (2.3 kg) fire extinguisher
- Battery disconnect
- Digital controller

AMBIENT CLIMATE RATINGS

- Wind rating: 65 mph (105 km/h)
- Air temperature ratings**
 - Standard units: 0°F to 120°F (-18°C to 49°C)
 - Units equipped with cold-weather options: -20°F to 120°F (-29°C to 49°C)

WARRANTY

- Tower: 1 year, unlimited hours/2 years, 2,000 hours
- LED modules and drivers: 5 year limited warranty

CERTIFICATIONS

- CSA certified

*Additional options may be available. Please contact a sales representative or the factory for current options.

**Environmental factors such as altitude, humidity, and engine fuel rating can impact temperature tolerance.

MLT4060MK/MLT4080K

MOBILE LIGHT TOWER

WEIGHTS & DIMENSIONS

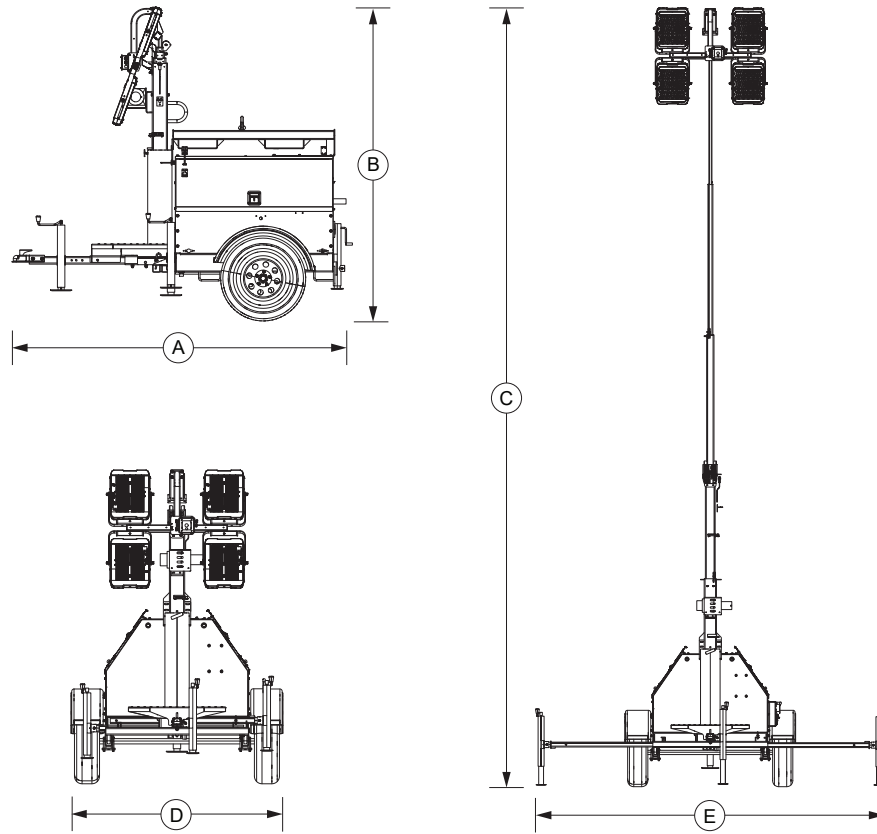

	A	B	C	D	E
	113 in (2.9 m)	102 in (2.6 m)	23.3 ft (7.11 m)	70 in (1.78 m)	140 in (3.56 m)
* All measurements are approximate and for estimation purposes only.					
		MLT4060M	MLT4060K	MLT4080K	
Weight Dry lb (kg)		1,655 (751)	1,675 (760)	1,720 (780)	
Weight Operating lb (kg)		2,058 (933)	2,078 (943)	2,123 (963)	

YOUR FACTORY RECOGNIZED GENERAC MOBILE DEALER

Specification characteristics may change without notice. Dimensions and weights are for preliminary purposes only. Please consult a Generac Mobile Authorized Service Dealer for detailed installation drawings.